

## SYNTRX EPROM adaptor assembly instructions

As the component count is low and the simplicity of the EPROM adaptor boards, these instructions are more of advice for the fitting of components to the bare boards. This information covers both the 24 pin and 28 pin EPROM boards.

1. The pins used and recommended are the standard square header pins available in strips of 1 by 40 way. The strips may be cut with sharp side cutters into the necessary lengths to suit the placement.
2. Those to fit to the SYNTRX prom socket need to be 9 pins long.
3. Those to fit for JU1 and JU2 are 3 or 6 pins long.
4. A single pin may be used for the +5 volt supply, or you may solder the + 5 volt wire directly to the board. However, you will need to be readily able to disconnect the +5 volt lead at one end or the other to allow easy removal and fitting of the adaptor board to the SYNTRX.
5. Before soldering any components to the board, place the bare board on a flat hard surface and place the short end of the 9-pin strip into the respective holes on the board. Using a small flat blade of a screwdriver or some other suitable flat tool, press the plastic strip holding the pins down against the board. Repeat the process for the 2<sup>nd</sup> 9-pin strip. This process moves the plastic strip closer to the end of the pins so that when the pins are soldered into place, the pins do not protrude through the top of the board. This serves two purposes, makes for a neater appearance and raises the board on the pins allowing for a good fit in the prom socket and the board clears the SYNTRX microcontroller IC.
6. It is recommended for ease of fitting and soldering of components, the components are fitted in the following order,
  - Resistors,
  - Transistor,
  - The 9 pin strips under the board,
  - IC socket, make sure you correctly orientate the socket with the notch above the +5 volt point.
  - +5 volt pin.
7. When fitting the 9 pin strips, it is recommended that you use a small piece of vero or matrix board or an 18 pin dual in line IC socket to hold the strips and pins square and at the correct spacing before soldering the pins from the top side of the board.
8. Once all components are fitted, fit the jumper shunts to JU1 and JU2.
9. A suitable connector for the +5 volt lead may be made using a jumper shunt. Press the metal insert out of the plastic and solder in the +5 volt lead wire in the position where one pin would normally fit. Be careful not to use too much solder or allow solder to flow into the other side of the insert. Press the insert back into the plastic surround and now you have a connector that should fit to a single header pin.

The diagrams below show the component placement of both versions of the adaptor boards. The component placement is also screen printed on the PCBs.

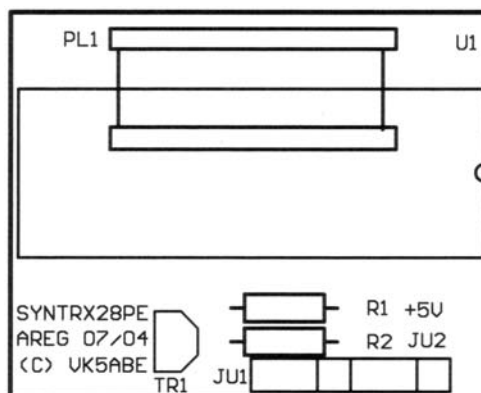
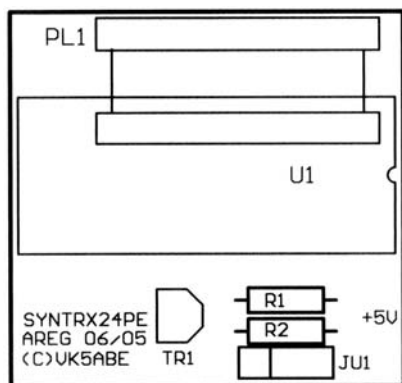

## Fitting the EPROM Adaptor board to the SYNTRX radio

The EPROM adaptor boards to suit either the 24 pin 2716 /32 or 28 pin 27XXx series EPROM's can be plugged directly into the SYNTRX U403 PROM socket.

The adaptor board needs + 5 volt supply for operation and this may be picked up from pin/pad 37 on the 2<sup>nd</sup> row of P100, the Option board interface, a double row of pads/pins just to the front of the microcontroller, U402. Check with a circuit for your version of the SYNTRX as there are several different board layouts for some early versions.

Solder the yellow wire supplied with the adaptor board, into the solder pad 37, which is the 4<sup>th</sup> from the end on the front row of pads, as indicated in the illustration below.

The other end of the yellow wire plugs onto the single pin on top of the adaptor board.

With a programmed EPROM fitted to the adaptor board, the board plugged into U403 socket and the yellow wire connected, this will complete the installation of the code Plug EPROM into the SYNTRX.

On the 24 pin EPROM board, the jumper must be set (grounded side, position A) to suit the 2716 or the 2732 Bank 1. On the 28 pin EPROM board, again either the jumpers or dip switch must be set to suit the EPROM (or memory bank). Refer to the Memory Bank Chart, Table 3.

All being well, when you turn on the radio, the channel display should show channel 1 and you should be able to toggle the channels up or down. If there is beeping from the speaker when the radio is turned on, this may be the 'out of lock' indication signal, meaning you will have to align the VCO to suit the new frequency range you have just added to the radio. Of course, if you have radically changed the frequencies, in other words the radio has not been re-aligned for the amateur frequencies, both the receiver and transmitter frequency multipliers and the receiver front end will also need to be re-aligned. Alignment information is available on the Motorola SYNTRX Service Sheets.

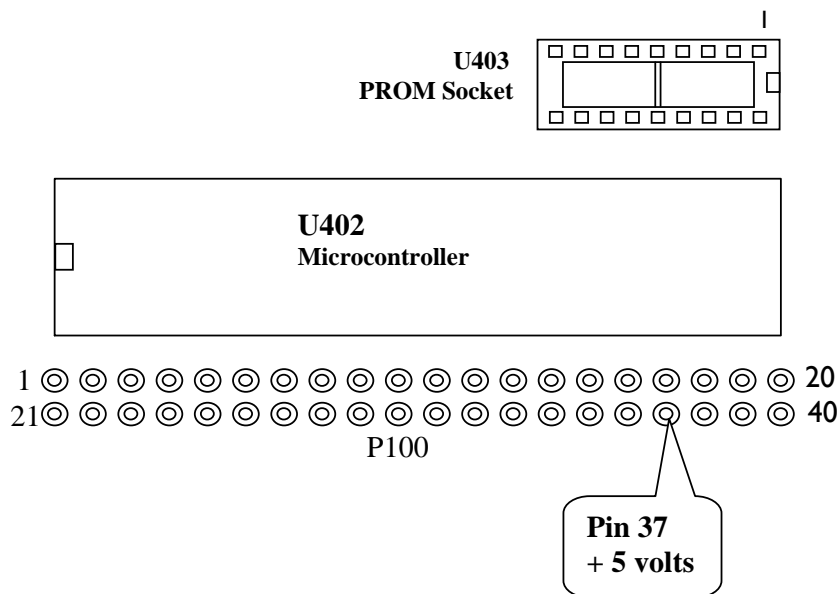

**Drawing 1.**

## SYNTRX EPROM Adaptor circuits

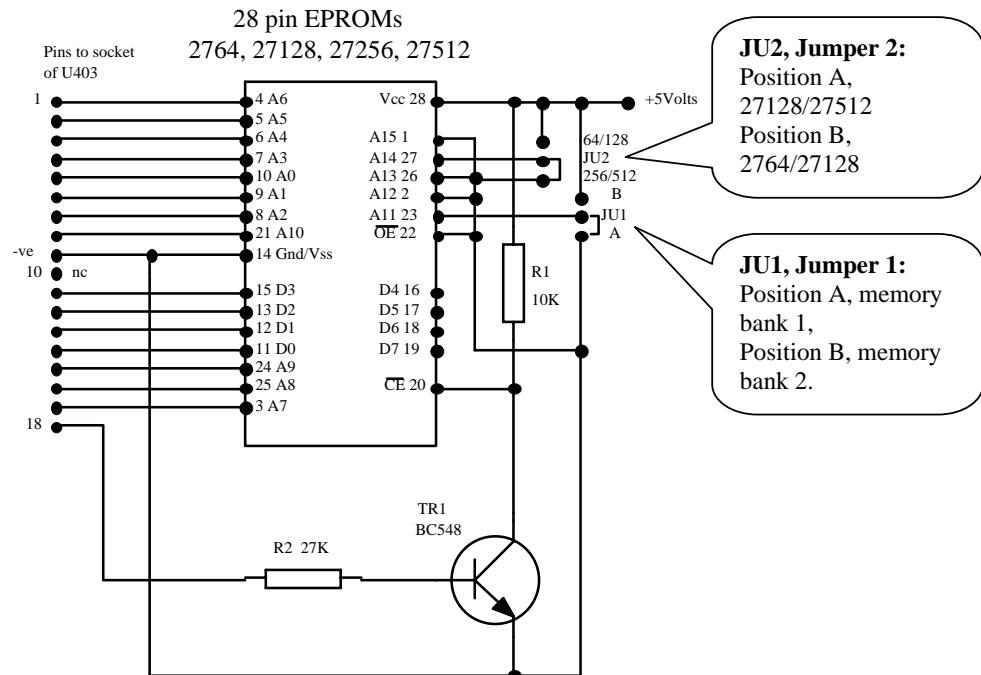
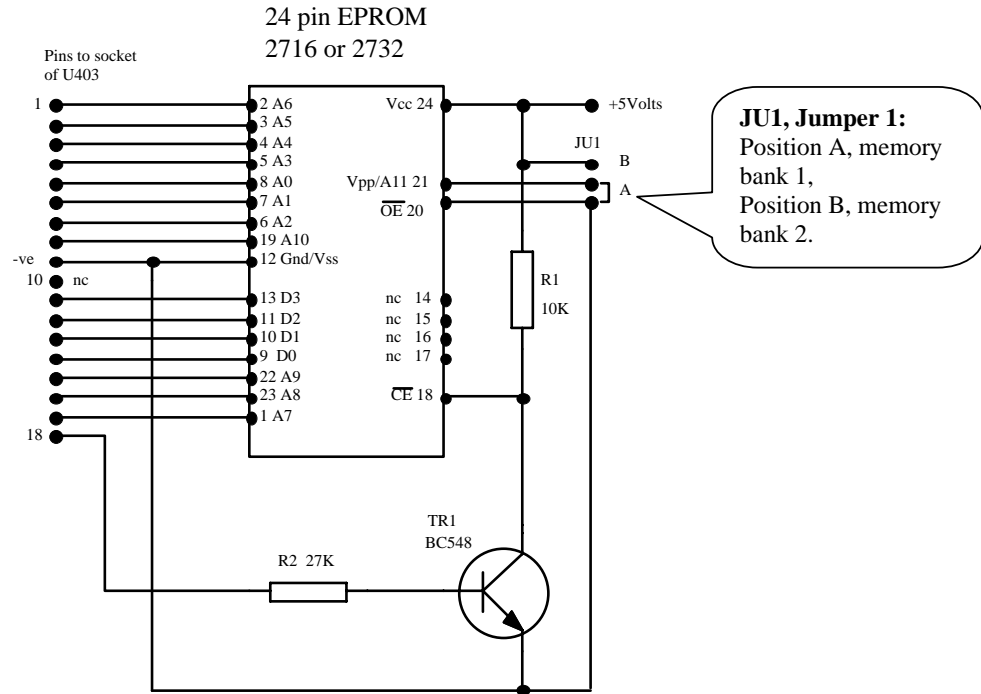

## SYNTRX EPROM Adaptor Jumper positions

JU 1, jumper 1, selects 2kb memory bank 1 or 2kb memory bank 2, only available if using 2732 + EPROMS. If using a 2716 EPROM, leave JU 1 in position A.

JU 2, jumper 2, on the 28 pin EPROMs selects for the size EPROM used,

- Position A, EPROMS 27512 or 27256,
- Position B, EPROMS 27128 or 2764.

24 pin EPROM adaptor..

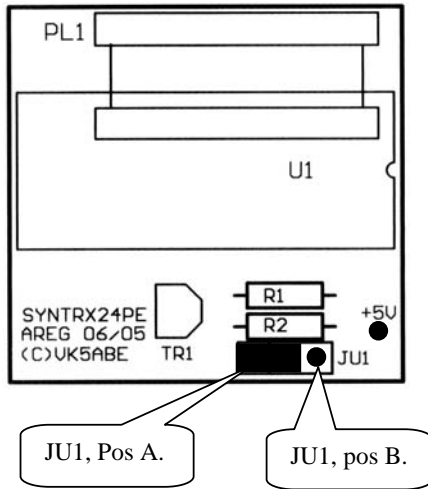

28 pin EPROM adaptor.

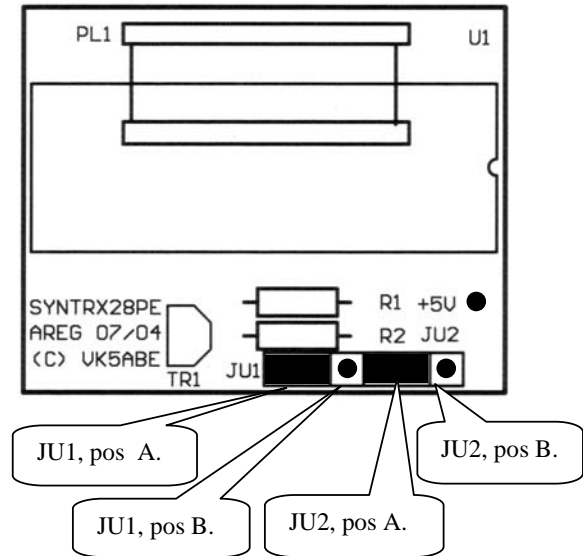

24 pin EPROM adaptor..

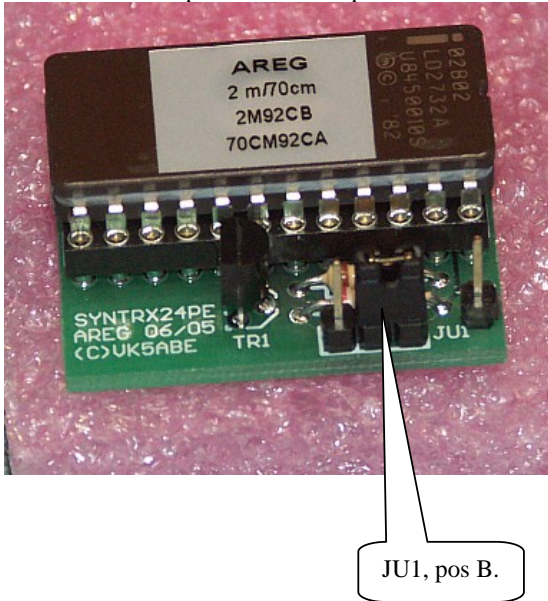

28 pin EPROM adaptor.

